



AiP74LVC2G14

Dual Inverter Schmitt Trigger

Product Specification

Specification Revision History:

Version	Date	Description
2017-05-A1	2017-05	New
2023-04-B1	2023-04	Update the template



Contents

1、 General Description.....	3
2、 Block Diagram And Pin Description	4
2.1、 Block Diagram	4
2.2、 Pin Configurations.....	4
2.3、 Pin Description	5
2.4、 Function Table.....	5
3、 Electrical Parameter	5
3.1、 Absolute Maximum Ratings.....	5
3.2、 Recommended Operating Conditions	6
3.3、 Electrical Characteristics	6
3.3.1、 DC Characteristics 1	6
3.3.2、 DC Characteristics 2	7
3.3.3、 AC Characteristics 1	7
3.3.4、 AC Characteristics 2	8
3.3.5、 Transfer Characteristics 1	8
3.3.6、 Transfer Characteristics 2	9
4、 Testing Circuit	9
4.1、 AC Testing Circuit	9
4.2、 AC Testing Waveforms.....	10
4.3、 Transfer Characteristics Waveforms	10
4.4、 Measurement Points	11
4.5、 Test Data	11
5、 Package Information	12
5.1、 SOT-23-6.....	12
5.2、 SOT-363.....	13
5.3、 XSON6.....	14
6、 Statements And Notes	15
6.1、 The name and content of Hazardous substances or Elements in the product.....	15
6.2、 Notes	15



1、 General Description

The AiP74LVC2G14 provides two inverting buffers with Schmitt-trigger input. It is capable of transforming slowly changing input signals into sharply defined, jitter-free output signals.

The inputs can be driven from either 3.3V or 5V devices. This feature allows the use of this device in a mixed 3.3V and 5V environment. Schmitt-trigger action at the inputs makes the circuit tolerant of slower input rise and fall time.

Features:

- Wide supply voltage range from 1.65V to 5.5V
- 5V tolerant inputs for interfacing with 5V logic
- $\pm 24\text{mA}$ output drive ($V_{CC}=3.0\text{V}$)
- CMOS low power consumption
- Direct interface with TTL levels
- Unlimited rise and fall times
- Specified from -40°C to $+125^{\circ}\text{C}$
- Packaging information: SOT-23-6/SOT-363/XSON6

Ordering Information:

Reel packing specifications:

Part number	Packaging form	Marking code	Reel quantity	Boxed reel quantity	Notes
AiP74LVC2G14GB236.TR	SOT-23-6	APXX	3000 PCS/reel	30000 PCS/box	Dimensions of plastic enclosure: 2.9mm×1.6mm Pin spacing: 0.95mm
AiP74LVC2G14GC363.TR	SOT-363	APXX	3000 PCS/reel	30000 PCS/box	Dimensions of plastic enclosure: 2.1mm×1.3mm Pin spacing: 0.65mm
AiP74LVC2G14EA6.TR	XSON6	APXX	5000 PCS/reel	25000 PCS/box	Dimensions of plastic enclosure: 1.45mm×1.0mm Pin spacing: 0.5mm

Note 1: "XX" refers to variable content, meaning year and package batch serial number.

Note 2: If the physical information is inconsistent with the ordering information, please refer to the actual product.



2、Block Diagram And Pin Description

2.1、Block Diagram

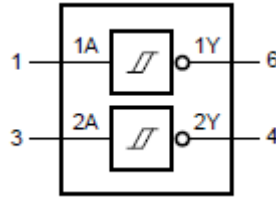

Figure 1. Logic symbol

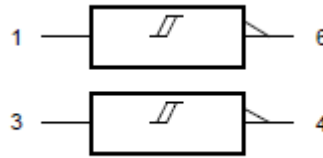

Figure 2. IEC logic symbol

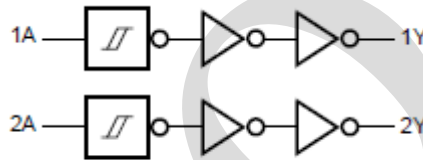
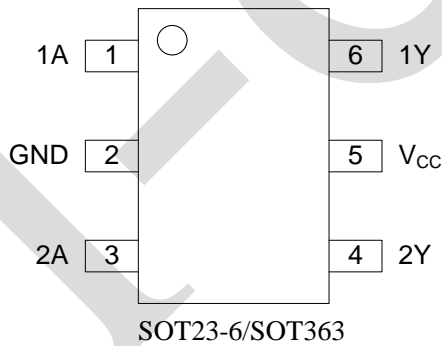
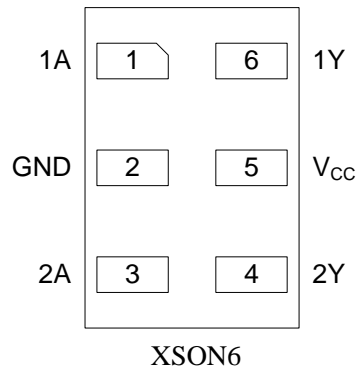

Figure 3. Logic diagram

2.2、Pin Configurations



SOT23-6/SOT363



XSON6



2.3、Pin Description

Pin No.	Pin Name	Description
1	1A	data input
2	GND	ground (0V)
3	2A	data input
4	2Y	data output
5	V _{CC}	supply voltage
6	1Y	data output

2.4、Function Table

Input	Output
nA	nY
L	H
H	L

Note: H=HIGH voltage level; L=LOW voltage level.

3、Electrical Parameter

3.1、Absolute Maximum Ratings

(Voltages are referenced to GND (ground=0V), unless otherwise specified.)

Parameter	Symbol	Conditions	Min.	Max.	Unit
supply voltage	V _{CC}	-	-0.5	+6.5	V
input voltage	V _I	-	-0.5	+6.5	V
output voltage	V _O	Active mode	-0.5	V _{CC} +0.5	V
		Power-down mode; V _{CC} =0V	-0.5	+6.5	V
input clamping current	I _{IK}	V _I < 0V	-50	-	mA
output clamping current	I _{OK}	V _O > V _{CC} or V _O < 0V	-	±50	mA
output current	I _O	V _O =0V to V _{CC}	-	±50	mA
supply current	I _{CC}	-	-	100	mA
ground current	I _{GND}	-	-100	-	mA
storage temperature	T _{stg}	-	-65	+150	°C
total power dissipation	P _{tot}	-	-	250	mW
soldering temperature	T _L	10s	260		°C



3.2、Recommended Operating Conditions

Parameter	Symbol	Conditions	Min.	Typ.	Max.	Unit
supply voltage	V_{CC}	-	1.65	-	5.5	V
input voltage	V_I	-	0	-	5.5	V
output voltage	V_O	Active mode	0	-	V_{CC}	V
		Power-down mode; $V_{CC}=0V$	0	-	5.5	V
ambient temperature	T_{amb}	-	-40	-	+125	°C

3.3、Electrical Characteristics

3.3.1、DC Characteristics 1

($T_{amb}=-40^{\circ}C$ to $+85^{\circ}C$, voltages are referenced to GND (ground=0V), unless otherwise specified.)

Parameter	Symbol	Conditions	Min.	Typ.	Max.	Unit	
HIGH-level output voltage	V_{OH}	$V_I = V_{T+}$ or V_{T-}	$I_O=-100\mu A$; $V_{CC}=1.65V$ to $5.5V$	V_{CC} 0.1	-	-	V
			$I_O=-4mA$; $V_{CC}=1.65V$	1.2	-	-	V
			$I_O=-8mA$; $V_{CC}=2.3V$	1.9	-	-	V
			$I_O=-12mA$; $V_{CC}=2.7V$	2.2	-	-	V
			$I_O=-24mA$; $V_{CC}=3.0V$	2.3	-	-	V
			$I_O=-32mA$; $V_{CC}=4.5V$	3.8	-	-	V
LOW-level output voltage	V_{OL}	$V_I = V_{T+}$ or V_{T-}	$I_O=100\mu A$; $V_{CC}=1.65V$ to $5.5V$	-	-	0.10	V
			$I_O=4mA$; $V_{CC}=1.65V$	-	-	0.45	V
			$I_O=8mA$; $V_{CC}=2.3V$	-	-	0.30	V
			$I_O=12mA$; $V_{CC}=2.7V$	-	-	0.40	V
			$I_O=24mA$; $V_{CC}=3.0V$	-	-	0.55	V
			$I_O=32mA$; $V_{CC}=4.5V$	-	-	0.55	V
input leakage current	I_I	$V_I=5.5V$ or GND; $V_{CC}=0V$ to $5.5V$	-	-	± 1	μA	
power-off leakage current	I_{OFF}	V_I or $V_O=5.5V$; $V_{CC}=0V$	-	-	± 2	μA	
supply current	I_{CC}	$V_I=5.5V$ or GND; $I_O=0A$; $V_{CC}=1.65V$ to $5.5V$	-	-	4	μA	
additional supply current	ΔI_{CC}	$V_I=V_{CC}-0.6V$; $I_O=0A$; $V_{CC}=2.3V$ to $5.5V$	-	-	500	μA	
input capacitance	C_I	$V_{CC}=3.3V$; $V_I=GND$ to V_{CC}	-	3.5	-	pF	

Note: All typical values are measured at maximum V_{CC} and $T_{amb}=25^{\circ}C$.



3.3.2、DC Characteristics 2

($T_{amb}=-40^{\circ}\text{C}$ to $+125^{\circ}\text{C}$, voltages are referenced to GND (ground=0V), unless otherwise specified.)

Parameter	Symbol	Conditions	Min.	Typ.	Max.	Unit	
HIGH-level output voltage	V_{OH}	$V_I = V_{T+}$ or V_{T-}	$I_O=-100\mu\text{A}; V_{CC}=1.65\text{V to }5.5\text{V}$	$V_{CC} - 0.1$	-	-	V
			$I_O=-4\text{mA}; V_{CC}=1.65\text{V}$	0.95	-	-	V
			$I_O=-8\text{mA}; V_{CC}=2.3\text{V}$	1.7	-	-	V
			$I_O=-12\text{mA}; V_{CC}=2.7\text{V}$	1.9	-	-	V
			$I_O=-24\text{mA}; V_{CC}=3.0\text{V}$	2.0	-	-	V
			$I_O=-32\text{mA}; V_{CC}=4.5\text{V}$	3.4	-	-	V
LOW-level output voltage	V_{OL}	$V_I = V_{T+}$ or V_{T-}	$I_O=100\mu\text{A}; V_{CC}=1.65\text{V to }5.5\text{V}$	-	-	0.10	V
			$I_O=4\text{mA}; V_{CC}=1.65\text{V}$	-	-	0.70	V
			$I_O=8\text{mA}; V_{CC}=2.3\text{V}$	-	-	0.45	V
			$I_O=12\text{mA}; V_{CC}=2.7\text{V}$	-	-	0.60	V
			$I_O=24\text{mA}; V_{CC}=3.0\text{V}$	-	-	0.80	V
			$I_O=32\text{mA}; V_{CC}=4.5\text{V}$	-	-	0.80	V
input leakage current	I_I	$V_I=5.5\text{V}$ or GND; $V_{CC}=0\text{V to }5.5\text{V}$	-	-	± 1	μA	
power-off leakage current	I_{OFF}	V_I or $V_O=5.5\text{V}; V_{CC}=0\text{V}$	-	-	± 2	μA	
supply current	I_{CC}	$V_I=5.5\text{V}$ or GND; $I_O=0\text{A}; V_{CC}=1.65\text{V to }5.5\text{V}$	-	-	4	μA	
additional supply current	ΔI_{CC}	$V_I=V_{CC}-0.6\text{V}; I_O=0\text{A}; V_{CC}=2.3\text{V to }5.5\text{V}$	-	-	500	μA	

3.3.3、AC Characteristics 1

($T_{amb}=-40^{\circ}\text{C}$ to $+85^{\circ}\text{C}$, voltages are referenced to GND (ground=0V), unless otherwise specified.)

Parameter	Symbol	Conditions	Min.	Typ. ^[1]	Max.	Unit	
nA to nY propagation delay	t_{PLH}	see Figure 5	$V_{CC}=1.65\text{V to }1.95\text{V}$	-	14	21	ns
			$V_{CC}=2.3\text{V to }2.7\text{V}$	-	10	15	ns
			$V_{CC}=2.7\text{V}$	-	9	13.5	ns
			$V_{CC}=3.0\text{V to }3.6\text{V}$	-	8	12	ns
			$V_{CC}=4.5\text{V to }5.5\text{V}$	-	7	10.5	ns
nA to nY propagation delay	t_{PHL}	see Figure 5	$V_{CC}=1.65\text{V to }1.95\text{V}$	-	12.5	18.8	ns
			$V_{CC}=2.3\text{V to }2.7\text{V}$	-	11	16.5	ns
			$V_{CC}=2.7\text{V}$	-	11	16.5	ns
			$V_{CC}=3.0\text{V to }3.6\text{V}$	-	11	16.5	ns
			$V_{CC}=4.5\text{V to }5.5\text{V}$	-	10	15	ns

Note:

[1] Typical values are measured at $T_{amb}=25^{\circ}\text{C}$ and $V_{CC}=1.8\text{V}, 2.5\text{V}, 2.7\text{V}, 3.3\text{V}$ and 5.0V respectively.



3.3.4、 AC Characteristics 2

($T_{amb}=-40^{\circ}\text{C}$ to $+125^{\circ}\text{C}$, voltages are referenced to GND (ground=0V), unless otherwise specified.)

Parameter	Symbol	Conditions	Min.	Typ. ^[1]	Max.	Unit	
nA to nY propagation delay	t_{PLH}	see Figure 5	$V_{CC}=1.65\text{V}$ to 1.95V	-	-	23	ns
			$V_{CC}=2.3\text{V}$ to 2.7V	-	-	17	ns
			$V_{CC}=2.7\text{V}$	-	-	15.5	ns
			$V_{CC}=3.0\text{V}$ to 3.6V	-	-	14	ns
			$V_{CC}=4.5\text{V}$ to 5.5V	-	-	12.5	ns
nA to nY propagation delay	t_{PHL}	see Figure 5	$V_{CC}=1.65\text{V}$ to 1.95V	-	-	20.8	ns
			$V_{CC}=2.3\text{V}$ to 2.7V	-	-	18.5	ns
			$V_{CC}=2.7\text{V}$	-	-	18.5	ns
			$V_{CC}=3.0\text{V}$ to 3.6V	-	-	18.5	ns
			$V_{CC}=4.5\text{V}$ to 5.5V	-	-	17	ns

Note:

[1] Typical values are measured at $T_{amb}=25^{\circ}\text{C}$ and $V_{CC}=1.8\text{V}$, 2.5V , 2.7V , 3.3V and 5.0V respectively.

3.3.5、 Transfer Characteristics 1

($T_{amb}=-40^{\circ}\text{C}$ to $+85^{\circ}\text{C}$, voltages are referenced to GND (ground = 0V), unless otherwise specified.)

Parameter	Symbol	Conditions	Min.	Typ.	Max.	Unit	
positive-going threshold voltage	V_{T+}	see Figure 6 and Figure 7	$V_{CC}=1.8\text{V}$	0.82	1.02	1.2	V
			$V_{CC}=2.3\text{V}$	1.03	1.25	1.45	V
			$V_{CC}=3.0\text{V}$	1.29	1.5	1.71	V
			$V_{CC}=4.5\text{V}$	1.84	2.15	2.41	V
			$V_{CC}=5.5\text{V}$	2.19	2.6	2.91	V
negative-going threshold voltage	V_{T-}	see Figure 6 and Figure 7	$V_{CC}=1.8\text{V}$	0.45	0.6	0.75	V
			$V_{CC}=2.3\text{V}$	0.64	0.8	0.96	V
			$V_{CC}=3.0\text{V}$	0.86	1.1	1.34	V
			$V_{CC}=4.5\text{V}$	1.35	1.75	2.09	V
			$V_{CC}=5.5\text{V}$	1.61	2.15	2.59	V
hysteresis voltage	V_H	$(V_{T+} - V_{T-})$; see Figure 6 and Figure 7	$V_{CC}=1.8\text{V}$	-	0.4	-	V
			$V_{CC}=2.3\text{V}$	-	0.4	-	V
			$V_{CC}=3.0\text{V}$	-	0.42	-	V
			$V_{CC}=4.5\text{V}$	-	0.45	-	V
			$V_{CC}=5.5\text{V}$	-	0.47	-	V



3.3.6、 Transfer Characteristics 2

($T_{amb}=-40^{\circ}\text{C}$ to $+125^{\circ}\text{C}$, voltages are referenced to GND (ground = 0V), unless otherwise specified.)

Parameter	Symbol	Conditions	Min.	Typ.	Max.	Unit	
positive-going threshold voltage	V_{T+}	see Figure 6 and Figure 7	$V_{CC}=1.8\text{V}$	0.79	-	1.2	V
			$V_{CC}=2.3\text{V}$	1.00	-	1.45	V
			$V_{CC}=3.0\text{V}$	1.26	-	1.71	V
			$V_{CC}=4.5\text{V}$	1.81	-	2.41	V
			$V_{CC}=5.5\text{V}$	2.16	-	2.91	V
negative-going threshold voltage	V_{T-}	see Figure 6 and Figure 7	$V_{CC}=1.8\text{V}$	0.45	-	0.78	V
			$V_{CC}=2.3\text{V}$	0.64	-	0.99	V
			$V_{CC}=3.0\text{V}$	0.86	-	1.37	V
			$V_{CC}=4.5\text{V}$	1.35	-	2.12	V
			$V_{CC}=5.5\text{V}$	1.61	-	2.62	V
hysteresis voltage	V_H	$(V_{T+} - V_{T-})$; see Figure 6 and Figure 7	$V_{CC}=1.8\text{V}$	-	0.4	-	V
			$V_{CC}=2.3\text{V}$	-	0.4	-	V
			$V_{CC}=3.0\text{V}$	-	0.42	-	V
			$V_{CC}=4.5\text{V}$	-	0.45	-	V
			$V_{CC}=5.5\text{V}$	-	0.47	-	V

4、 Testing Circuit

4.1、 AC Testing Circuit

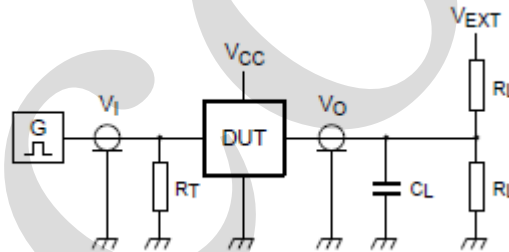

Figure 4. Test circuit for measuring switching times

Definitions for test circuit:

R_L =Load resistance.

C_L =Load capacitance including jig and probe capacitance.

R_T =Termination resistance; should be equal to the output impedance Z_o of the pulse generator.

V_{EXT} =External voltage for measuring switching times.



4.2、 AC Testing Waveforms

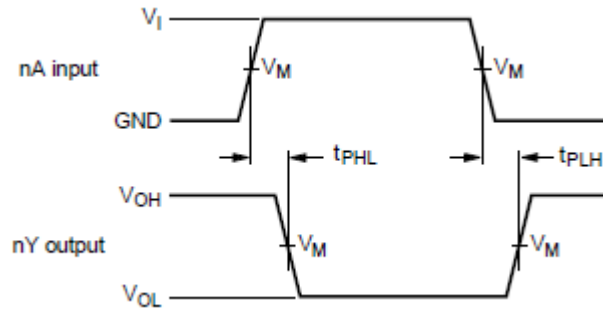

Figure 5. The input nA to output nY propagation delays

4.3、 Transfer Characteristics Waveforms

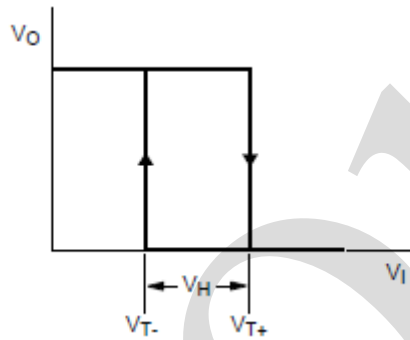

Figure 6. Transfer characteristic

V_{T+} and V_{T-} limits at 70% and 20%:

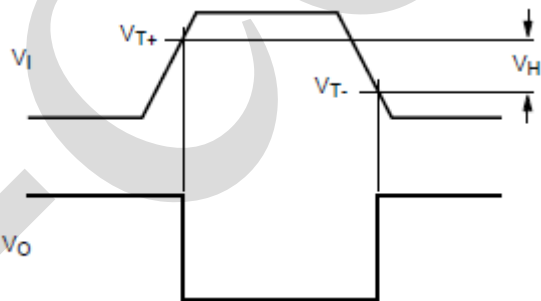

Figure 7. Definition of V_{T+} , V_{T-} and V_H



4.4、Measurement Points

Supply voltage	Input	Output
V_{CC}	V_M	V_M
1.65V to 1.95V	$0.5 \times V_{CC}$	$0.5 \times V_{CC}$
2.3V to 2.7V	$0.5 \times V_{CC}$	$0.5 \times V_{CC}$
2.7V	1.5V	1.5V
3.0V to 3.6V	1.5V	1.5V
4.5V to 5.5V	$0.5 \times V_{CC}$	$0.5 \times V_{CC}$

4.5、Test Data

Supply voltage	Input		Load		V_{EXT}
	V_I	$t_r = t_f$	C_L	R_L	t_{PLH}, t_{PHL}
1.65V to 1.95V	V_{CC}	$\leq 3ns$	30pF	1k Ω	open
2.3V to 2.7V	V_{CC}	$\leq 3ns$	30pF	500 Ω	open
2.7V	2.7V	$\leq 3ns$	50pF	500 Ω	open
3.0V to 3.6V	2.7V	$\leq 3ns$	50pF	500 Ω	open
4.5V to 5.5V	V_{CC}	$\leq 3ns$	50pF	500 Ω	open



5、Package Information

5.1、SOT-23-6

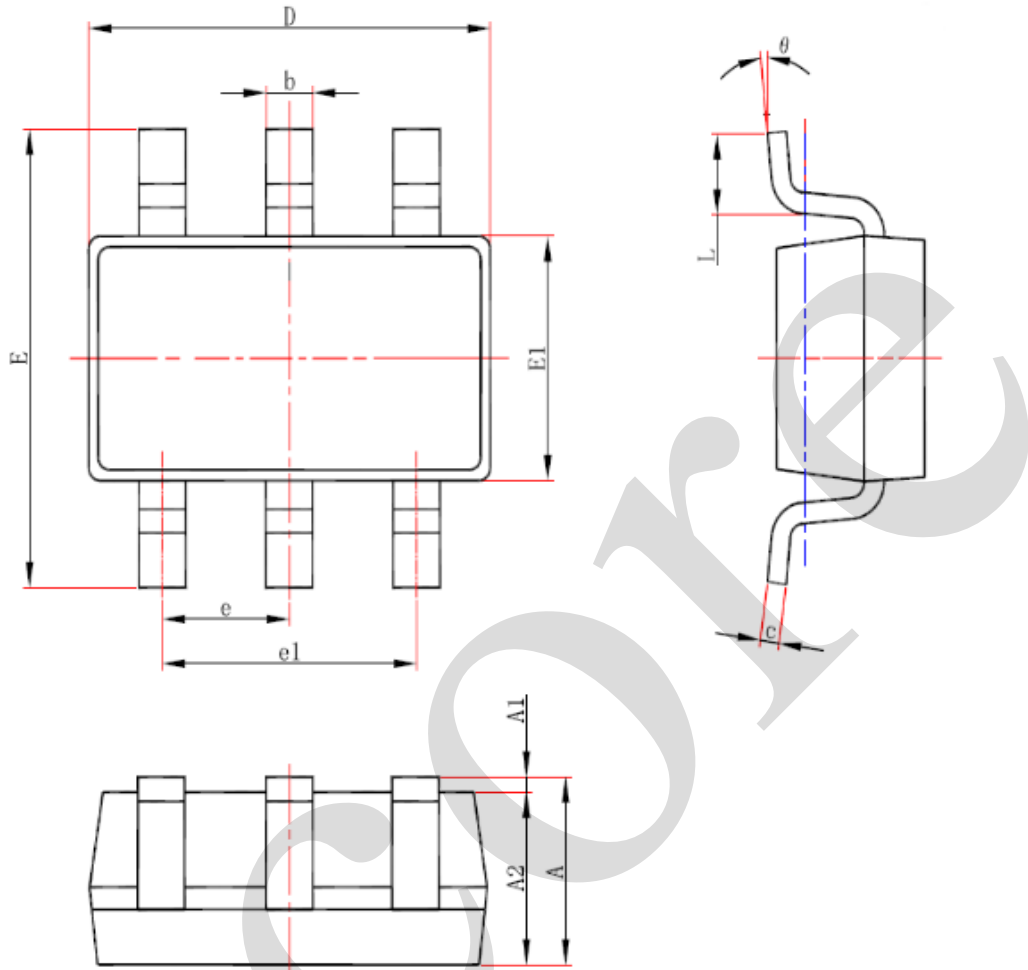

Symbol	Dimensions (mm)	
	Min.	Max.
A	-	1.25
A1	0.00	0.12
A2	1.00	1.20
b	0.30	0.50
c	0.10	0.20
D	2.82	3.02
E	2.60	3.00
E1	1.50	1.70
e	0.95	
e1	1.80	2.00
L	0.30	0.60
θ	0°	8°



5.2、SOT-363

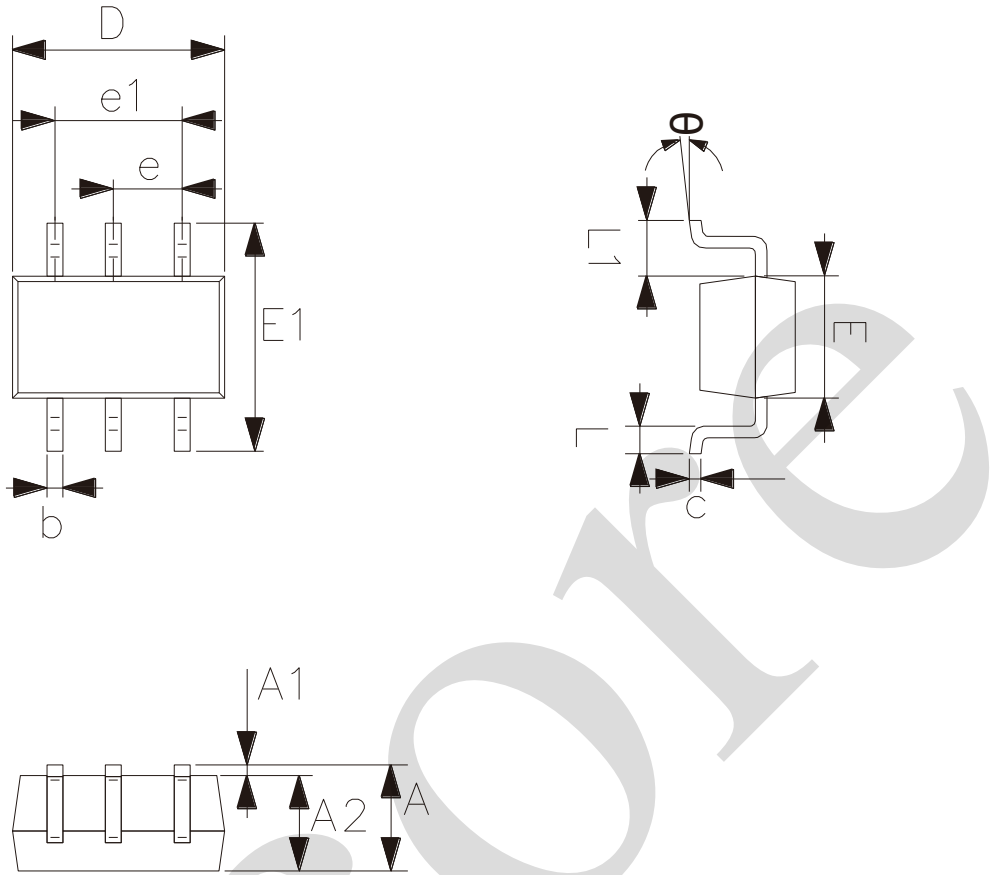

Symbol	Dimensions (mm)	
	Min.	Max.
A	0.90	1.10
A1	0.00	0.10
A2	0.90	1.00
b	0.15	0.35
c	0.11	0.175
D	2.00	2.20
E1	2.15	2.45
E	1.15	1.35
e	0.65	
e1	1.20	1.40
L	0.26	0.46
L1	0.525	
θ	0°	8°



5.3、XSON6

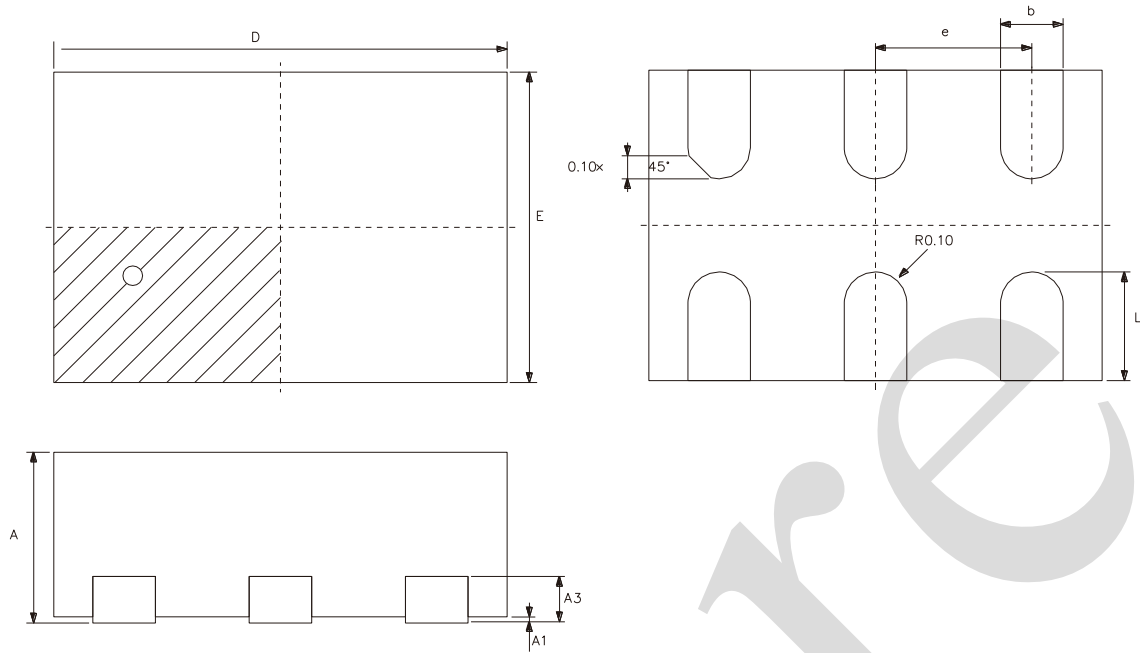

Symbol	Dimensions (mm)	
	Min.	Max.
A	0.51	0.60
A1	0.00	0.05
A3	0.15	
b	0.15	0.25
D	1.45	
E	1.00	
e	0.50	
L	0.25	0.45



6、 Statements And Notes

6.1、 The name and content of Hazardous substances or Elements in the product

Part name	Hazardous substances or Elements									
	Lead and lead compounds	Mercury and mercury compounds	Cadmium and cadmium compounds	Hexavalent chromium compounds	Polybrominated biphenyls	Polybrominated biphenyl ethers	Dibutyl phthalate	Butylbenzyl phthalate	Di-2-ethylhexyl phthalate	Diisobutyl phthalate
Lead frame	○	○	○	○	○	○	○	○	○	○
Plastic resin	○	○	○	○	○	○	○	○	○	○
Chip	○	○	○	○	○	○	○	○	○	○
The lead	○	○	○	○	○	○	○	○	○	○
Plastic sheet installed	○	○	○	○	○	○	○	○	○	○
explanation	○: Indicates that the content of hazardous substances or elements in the detection limit of the following the SJ/T11363-2006 standard. ×: Indicates that the content of hazardous substances or elements exceeding the SJ/T11363-2006 Standard limit requirements.									

6.2、 Notes

We Recommend you to read this chapter carefully before using this product.

The information in this chapter is provided for reference only and i-Core disclaims any express or implied warranties, including but not limited to applicability, special application or non-infringement of third party rights.

This product is not suitable for critical equipment such as life-saving, life-sustaining or safety equipment. It is also not suitable for applications that may result in personal injury, death, or serious property or environmental damage due to product malfunction or failure. I-Core will not be liable for any damages incurred by the customers at their own risk for such applications.

The customer is responsible for conducting all necessary tests i-Core's application to avoid failure in the application or the application of the customer's third party users. I-Core does not accept any liability.

The Company reserves the right to change or improve the information published in this chapter at any time. The information in this chapter are subject to change without notice. We recommend the customer to consult our sales staff before purchasing.

Please obtain related materials form i-Core's regular channels and we are not responsible for its content if it is provided by sources other than our company.

In case of any conflict between the Chinese and English version, the version is subject to the Chinese one.